

CZ	PŮDNÍ SCHODY	LV	BĒNIŅU KĀPNES
DE	BODENTREPPE	NL	ZOLDER/VLIERINGTRAP
EE	PÕÕNINGUREDEL	PL	SCHODY STRYCHOWE
ES	ESCALERAS ESCAMOTEABLES	PT	ESCADA DE SOTAO-ENCAIXADA
FR	ESCALIER ESCAMOTABLE	RO	SCARĂ MODULARĂ
GB	LOFT LADDER	RU	ЧЕРДАЧНАЯ ЛЕСТНИЦА
HU	PADLÁSFELJÁRÓ LÉPCSŐ	SI	PODSTREŠNE SLOPLJIVE STOPNICE
IT	LE SCALE PER LA SOFFITTA	SK	STROPNÉ SKLÁPACIE SCHODY
LT	PALĖPĖS LAIPTELIAI	US	ATTICSTAIRS

# OLN

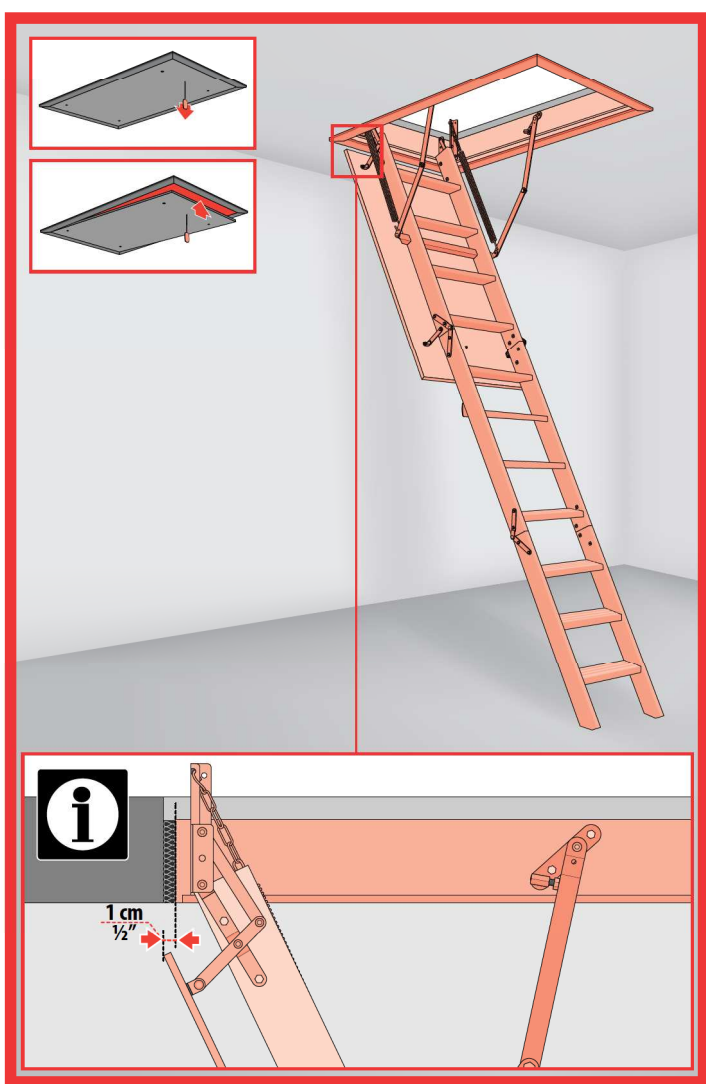

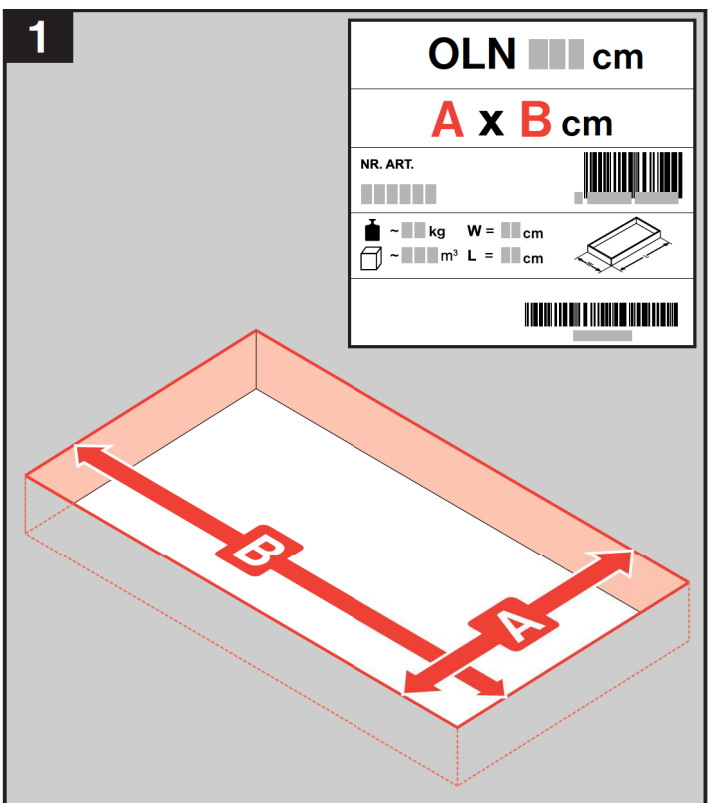
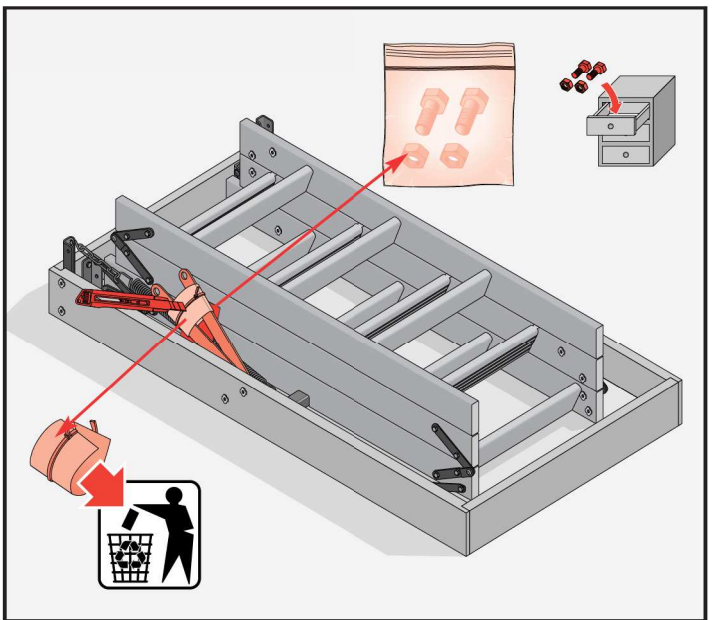
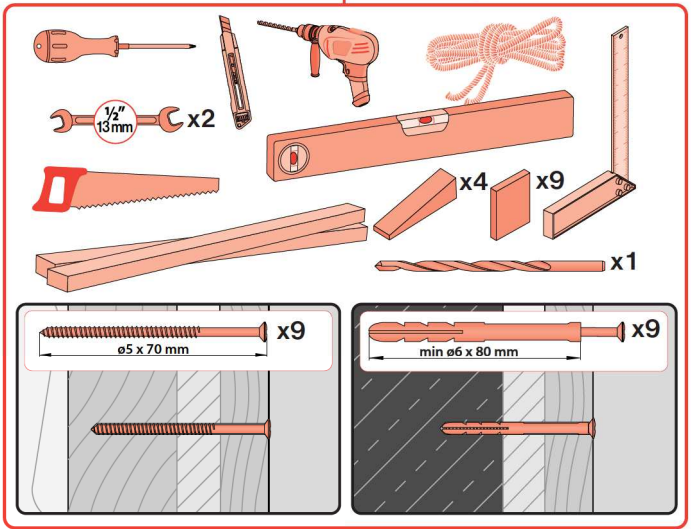

2

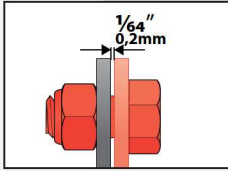
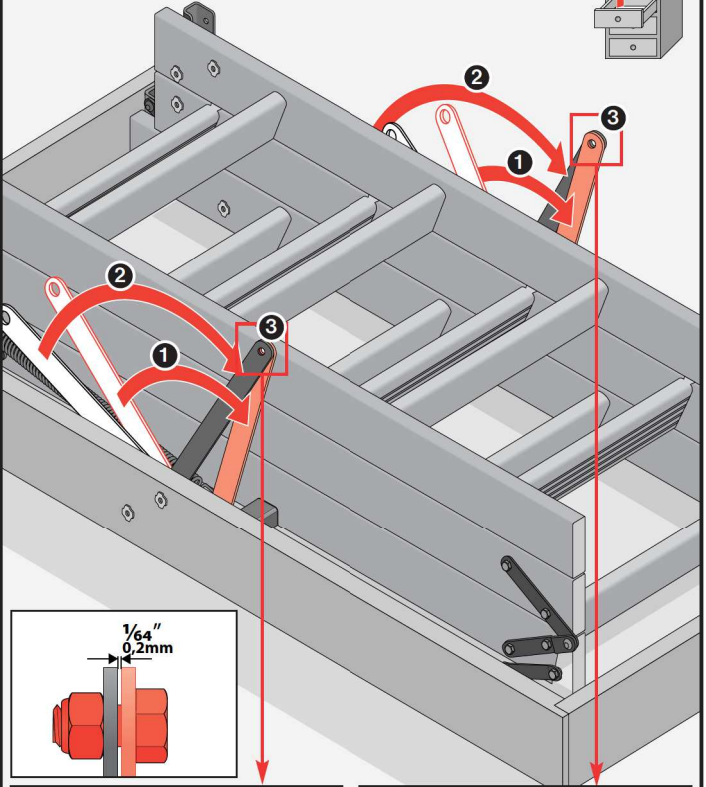
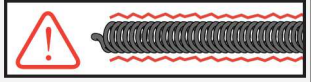
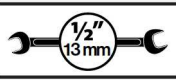

**L**

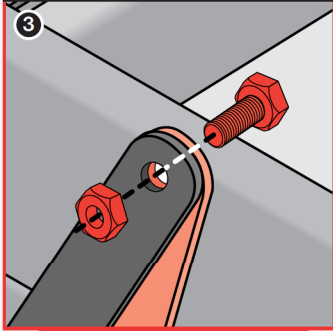

**R**

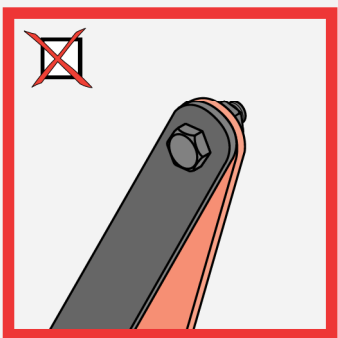
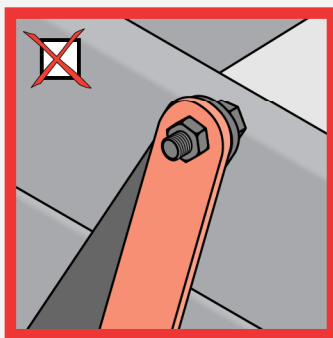
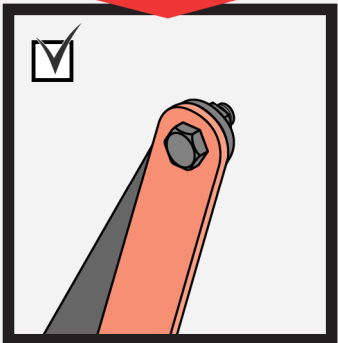
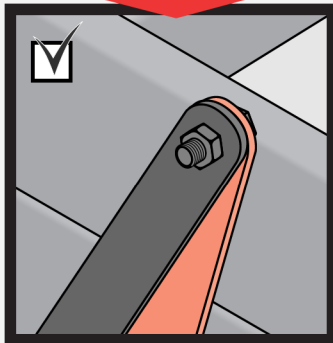
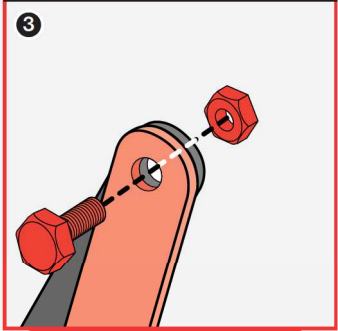

3a

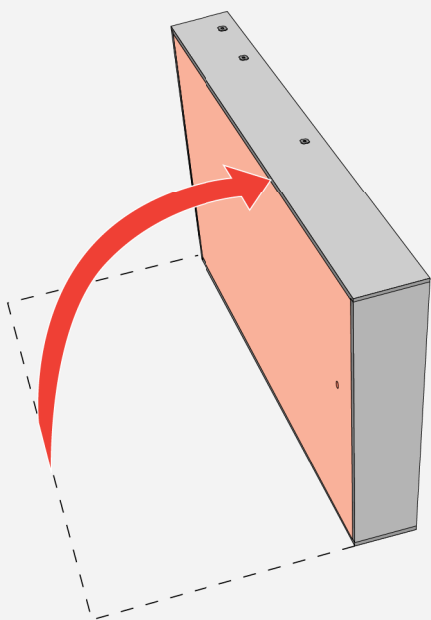

3b

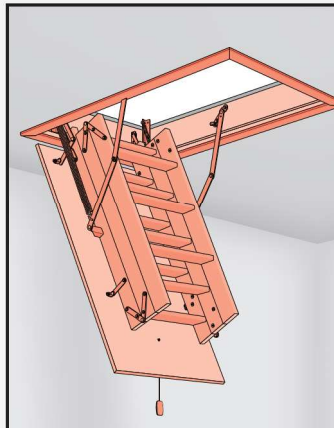
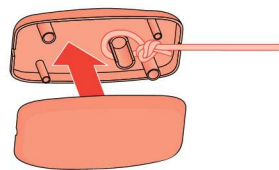
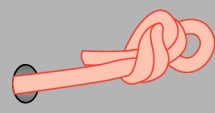
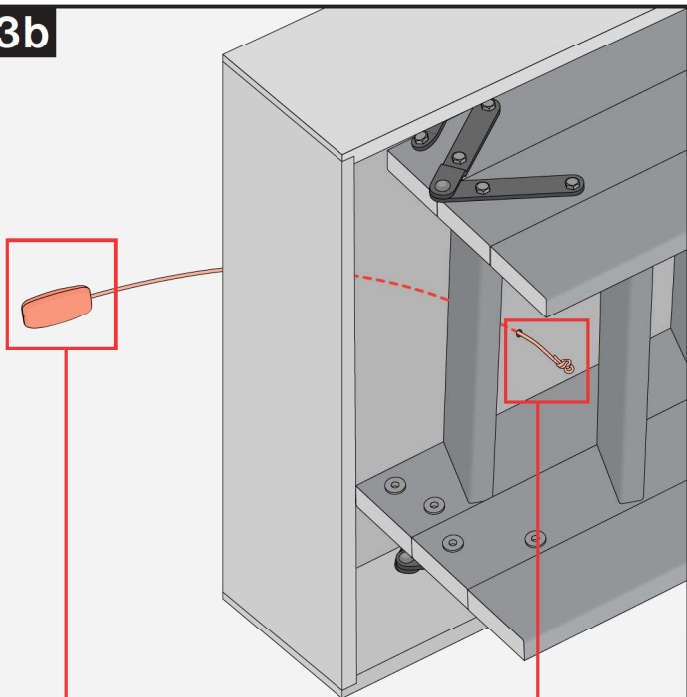

4

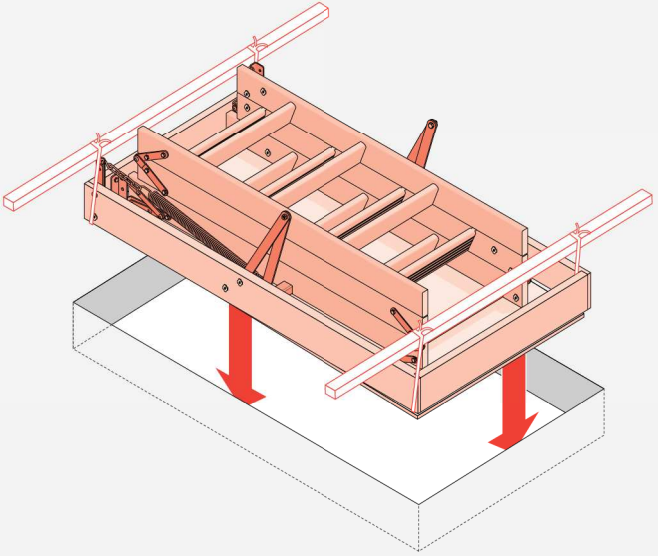

5

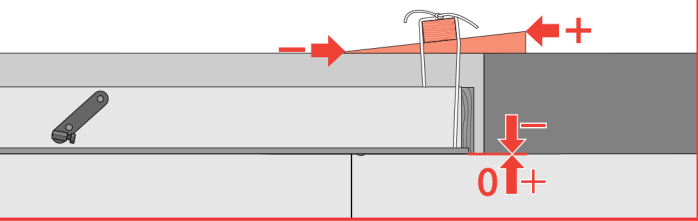
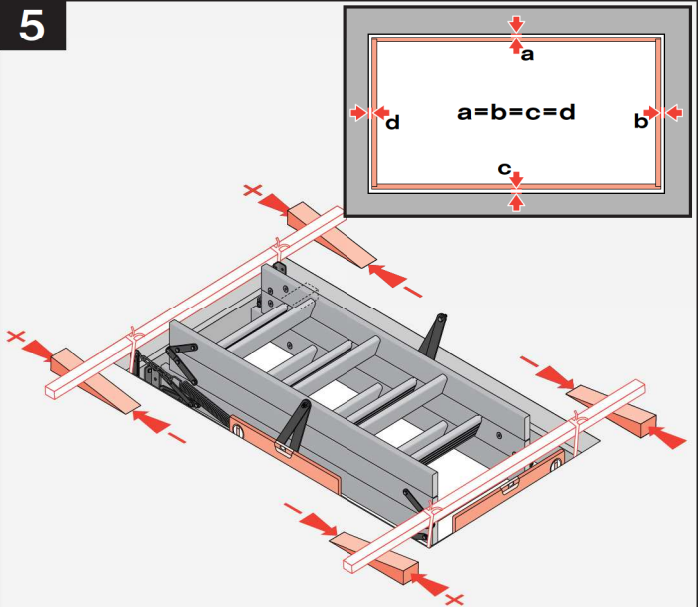

6

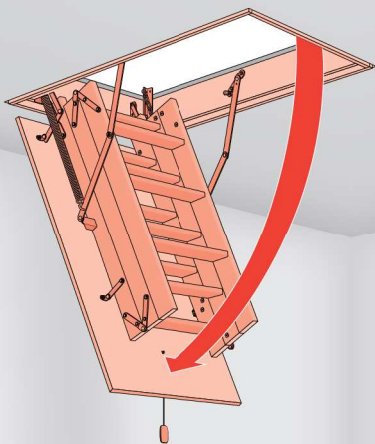

7

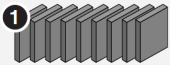

7\*

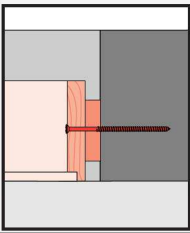
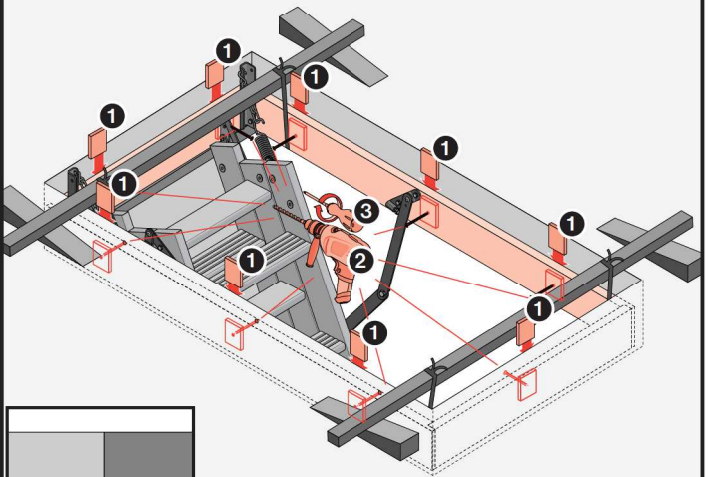
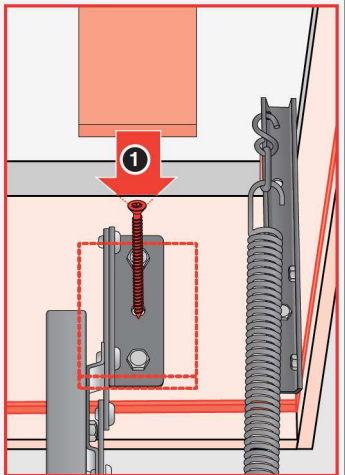
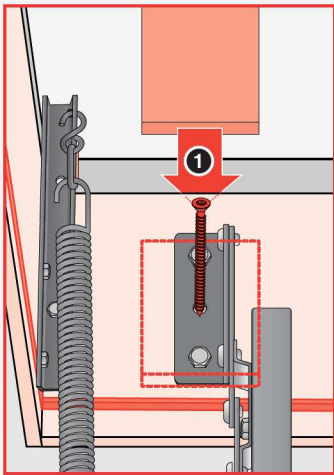

7\*

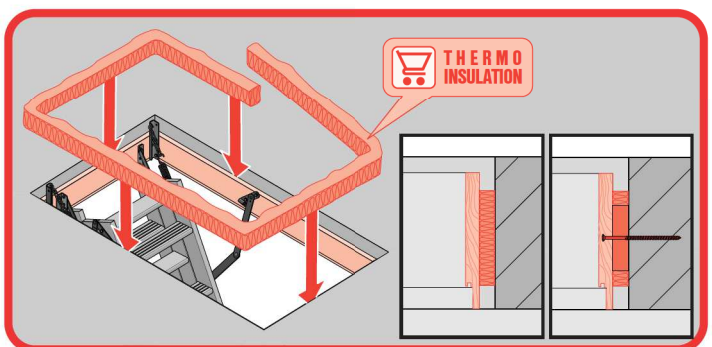
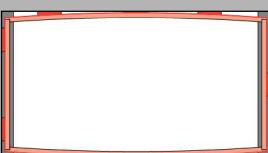
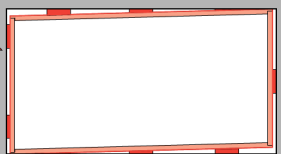

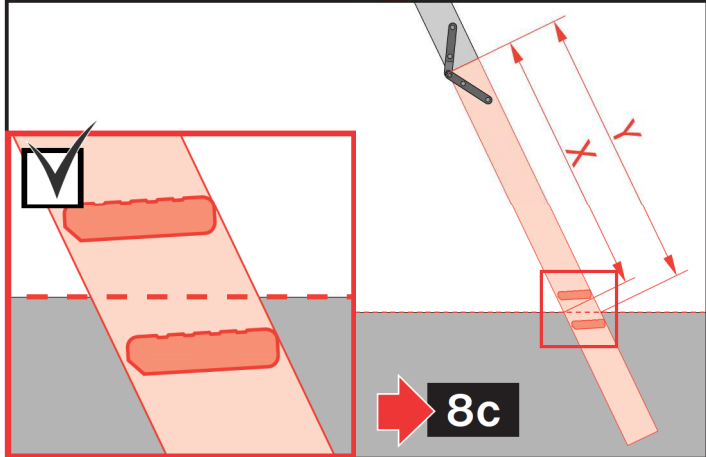
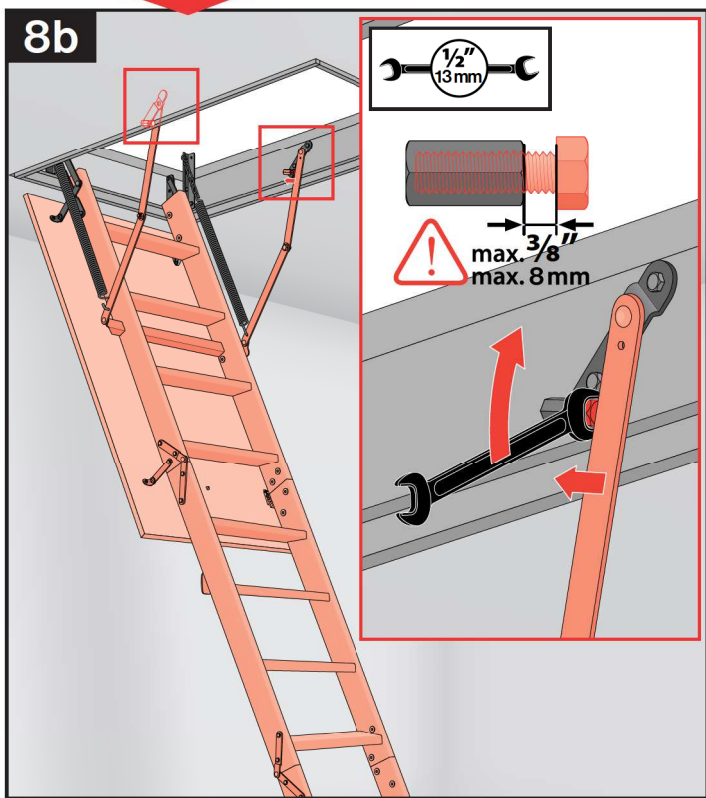
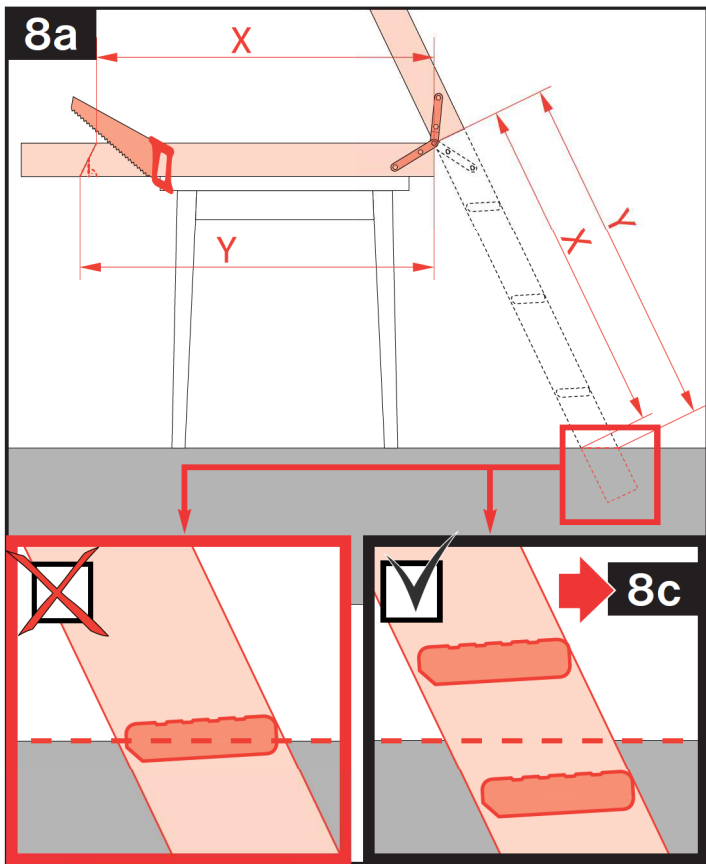

8c

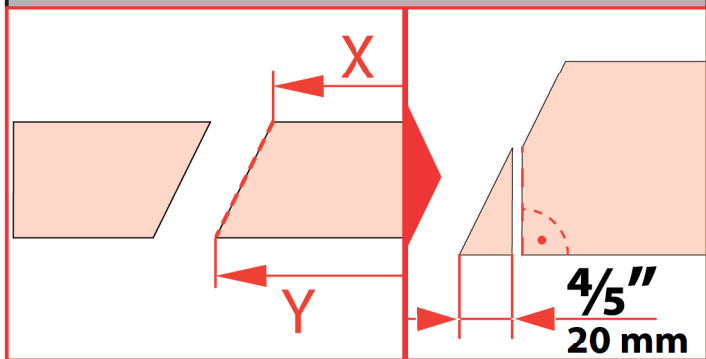
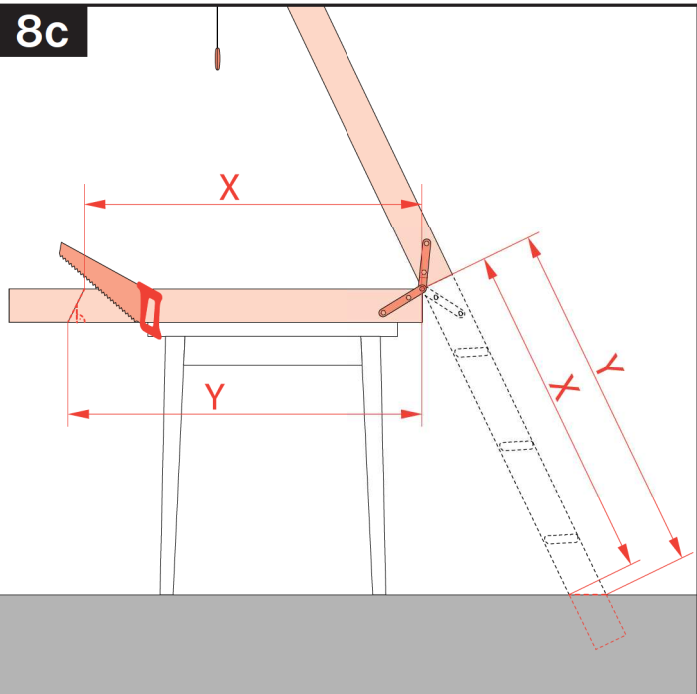

9a

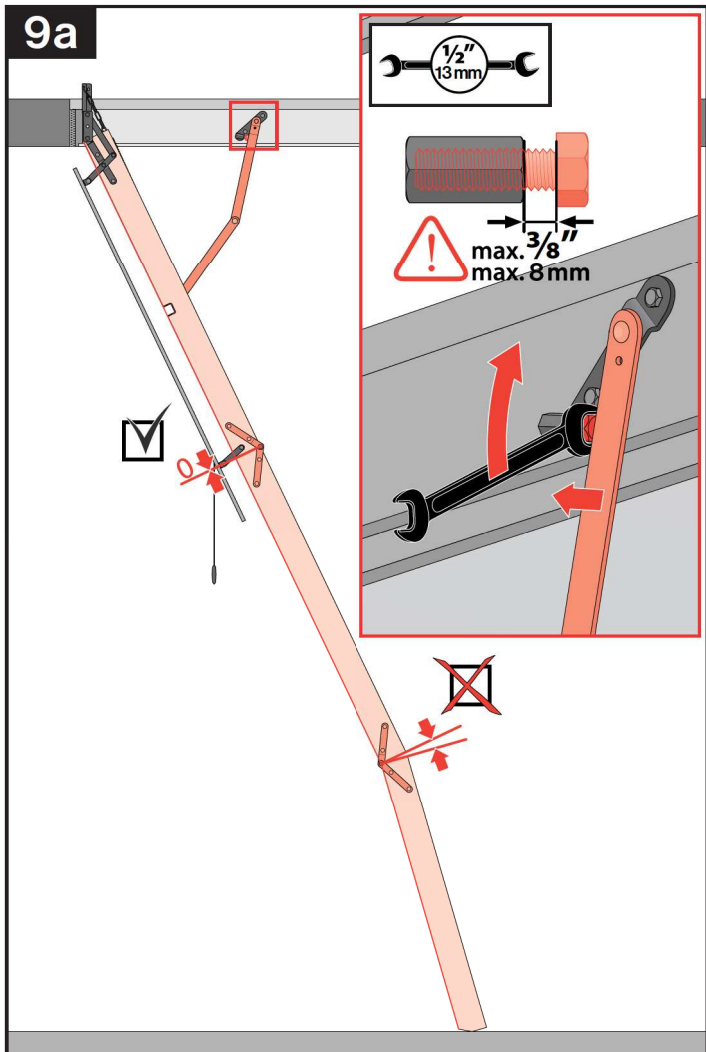



9b

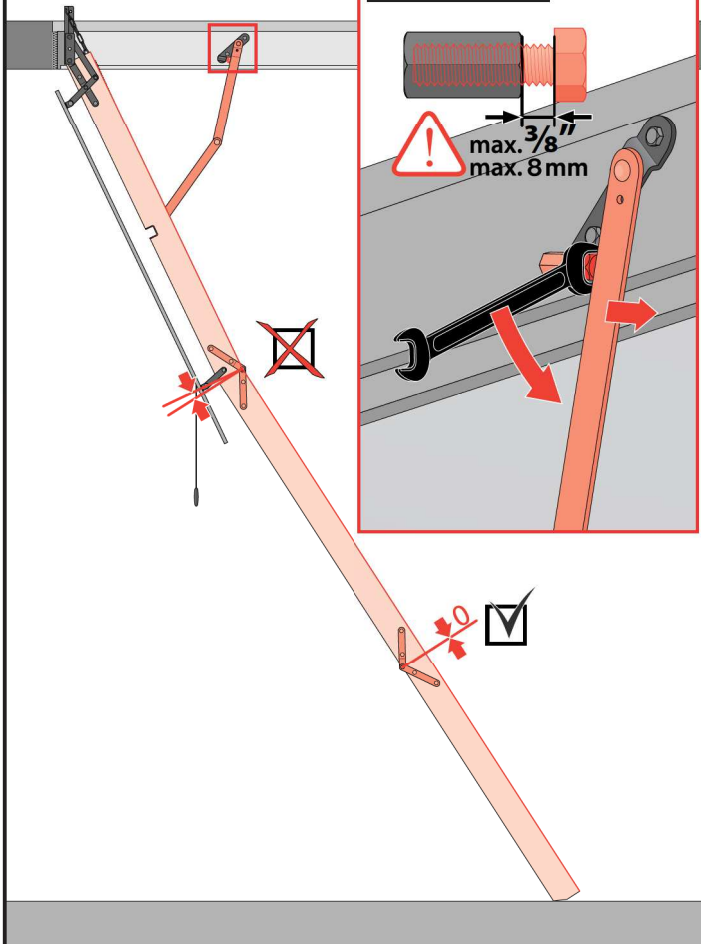
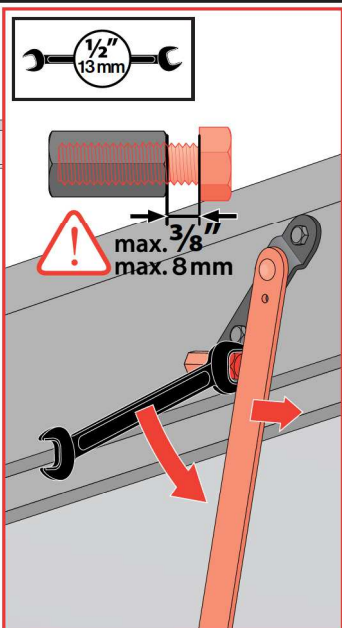

9c

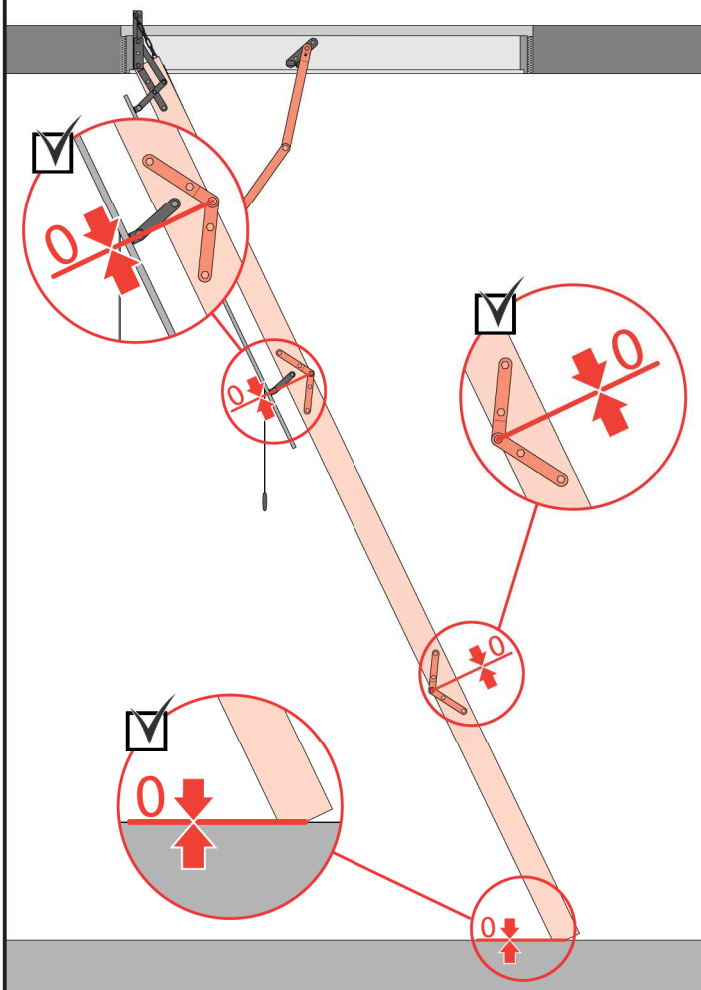

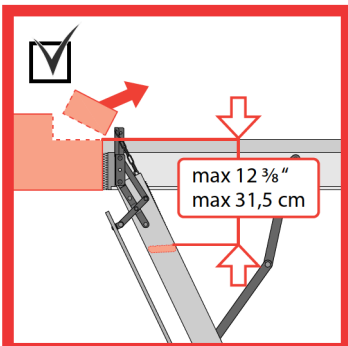
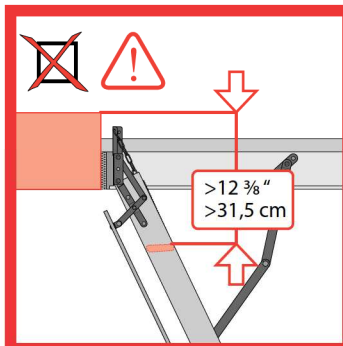
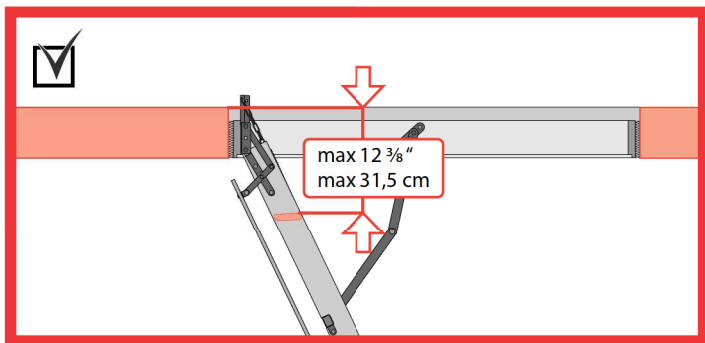

**DE** Bodentreppen sind erst nach der Ausführung von feuchten Bauarbeiten einzubauen, wenn die Baufeuchte wieder auf ein für Aufenthaltsräume normales Maß zurückgegangen ist. Die Bodentreppen sind nur für Verwendung in trockenen Innenräumen geeignet.

**EE** Pööninguredel on ette nähtud paigaldamiseks peale "märgade" sisetööde lõpetamist

kui niiskustase on normaliseerunud. Pööninguredelit võib kasutada ainult kuivades siseruumides.

**ES** La escalera se debe instalar una vez que la instalación se encuentre totalmente seca. Se aconseja montar la escalera en la estancia donde la humedad esta por debajo de 80%. Las escaleras son para uso en interior y en espacios secos.

**FR** L'escalier doit être monté après la finition des travaux de finition humide, lorsque l'humidité dans le bâtiment atteint une valeur appropriée pour locaux secs. Escaliers sont destinés à usage interne et uniquement dans les endroits secs.

**GB** The loft ladder should be installed after completion of wet works, when the humidity in the building reaches the value appropriate for dry rooms. Loft ladders are designed for the interior use and only in dry rooms.

**LT** Palėpės laiptus reikia montuoti name užbaigus šlapius statybos procesus, ir tik tada kai drėgmė patalpoje atitinka sauso namo reikalavimus. Palėpės laiptus galima montuoti tik namo viduje ir sausoje patalpoje.

**LV** Bēniņu kāpnes drīkst uzstādīt tikai pēc tam, kad pabeigti ar mitruma izdalīšanas saistītie celtniecības darbi, un mitruma līmenis ēkā ir sasniedzis sausām telpām paredzēto. Bēniņu kāpnes ir piemērotas iekšējām un tikai sausām telpām.

**PL** Schody należy montować po zakończeniu prac mokrych, gdy wilgotność w budynku osiągnie wartość właściwą dla pomieszczeń suchych. Schody przeznaczone są do użytku wewnętrznego i tylko w suchych pomieszczeniach.

**RU** Лестницу монтировать после завершения всех отделочных работ, то есть тогда, когда влажность в здании достигнет значения, соответствующего значению влажности в сухом помещении. Лестница предназначена для установки внутри сухого помещения.



# ! WARNING! - ACHTUNG! - UWAGA! - ATTENTION! - CUIDADO! - ВНИМАНИЕ!

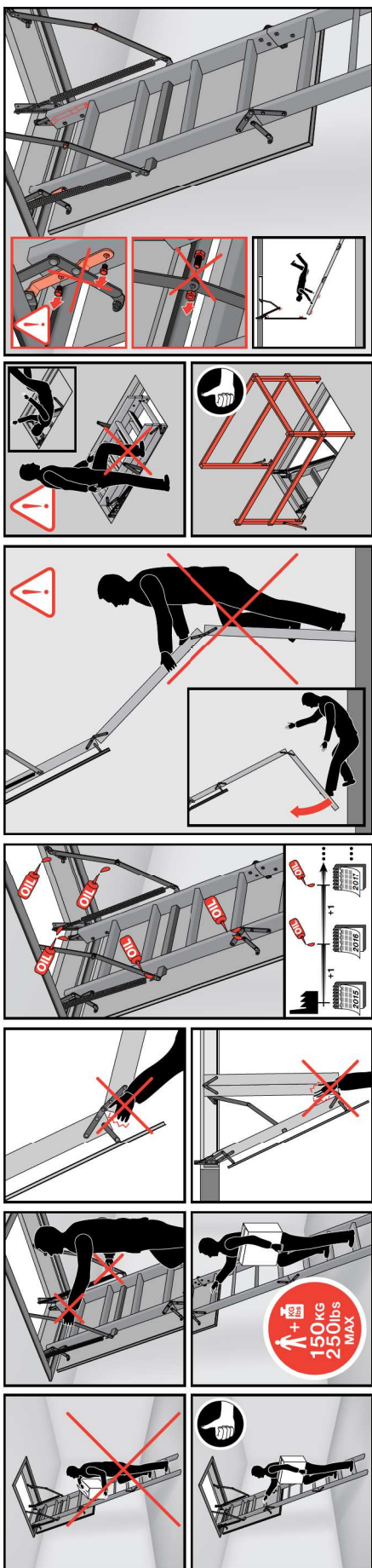

<b>CZ</b>	Výrobce ani prodejce nenesou žádnou odpovědnost za nedodržání příslušných právních předpisů, stavebních předpisů a bezpečnostních požadavků uživatelem výrobku, architektem, montážníkem nebo vlastníkem budovy.	<b>NL</b>	De fabrikant en verkoper zijn niet aansprakelijk voor gevolgen bij het niet opvolgen van toepasselijke wetten, bouwvoorschriften en veiligheidsvoorschriften door de gebruiker van het product, de architect, de installateur of de eigenaar van het gebouw.
<b>DE</b>	Hersteller und Verkäufer übernehmen keine Haftung für Nichtbeachtung entsprechender Rechts- und Bauvorschriften sowie Sicherheitsanforderungen seitens Produktbenutzers, Architekten, Monteure oder Gebäudebesitzer.	<b>PL</b>	Producent i Sprzedawca nie ponosi żadnej odpowiedzialności za nieprzestrzeganie stosownych przepisów prawa, przepisów budowlanych i wymogów bezpieczeństwa przez użytkownika produktu, architekta, montażystę lub właściciela budynku.
<b>ES</b>	El fabricante y el vendedor no tienen ninguna responsabilidad por el incumplimiento de la ley vigente, normas de construcción y exigencias de seguridad por parte del usuario del producto, arquitecto, instalador o el propietario del edificio.	<b>PT</b>	O fabricante e o vendedor não tem nenhuma responsabilidade pelo o não cumprimento da lei, códigos de construção e as exigências de segurança por parte do usuário do produto, arquiteto, instalador ou proprietário do edifício.
<b>FR</b>	Le fabricant et le revendeur ne prend aucune responsabilité de ne pas respecter les lois applicables, les règlements sur les bâtiments et les exigences de sécurité par l'utilisateur du produit, l'architecte, l'installateur ou le propriétaire du bâtiment.	<b>RO</b>	Nici producătorul, nici distribuitorul nu își vor asuma niciun fel de răspundere pentru nerespectarea legilor în vigoare, a legilor din domeniul construcțiilor sau a măsurilor de siguranță impuse utilizatorilor produsului, arhitecților, montajorilor sau proprietarilor clădirii.
<b>GB</b>	Manufacturer and Seller shall bear no liability for failure to comply with the applicable laws, building codes and safety requirements by the user of the product, architect, fitter or owner of the building.	<b>RU</b>	В случае несоблюдения архитектором, монтажником или владельцем здания строительных правил и норм безопасности ответственность с производителя и продавца снимается.
<b>HU</b>	A Gyártó és a Forgalmazó nem vállal semmiféle felelősséget a vonatkozó törvényi, építési és biztonsági előírások termékfelhasználó, építész, beépítőmester vagy épülettulajdonos általi nem tartásáért.	<b>SK</b>	Výrobca a predajca nenesú žiadnu zodpovednosť za nedodržanie príslušných ustanovení zákona, stavebných predpisov a bezpečnostných požiadaviek užívateľom výrobku, architektom, montérom alebo majiteľom objektu.
<b>IT</b>	Il Produttore e il Rivenditore non potranno essere ritenuti responsabili per il mancato rispetto, da parte dell'utente del prodotto, del progettista, dell'installatore o del proprietario dell'edificio, delle leggi vigenti, nonché dei regolamenti edilizi e di quelli relativi alla sicurezza.		